

VT Series 3-Way Ball Valves

Product Data Sheet



< STANDARDS >



ASTM D1784
ASTM D4101-86
ASTM D2466
ASTM D2467
ASTM D2464
ASTM F1498



ISO 3609



ANSI B1.20.1
ANSI B16.5

introduction

IPEX VT Series 3-Way Ball Valves can be used for flow diverting, mixing, or on/off isolation. They will replace a Tee + 2 valve linkage assembly at reduced cost and space, along with shorter installation and maintenance time. Molded features on the body allow for simple mounting and actuation while in-line ball seat adjustments are easily achieved by tightening the union nuts. VT Series 3-Way Ball Valves are part of our complete systems of pipe, valves, and fittings, engineered and manufactured to our strict quality, performance, and dimensional standards

Valve Availability

Body Material:	PVC, PP
Size Range:	1/2" through 2"
Pressure:	150 psi
Seats:	Teflon® (PTFE)
Seals:	EPDM or Viton® (FPM)
End Connections:	Socket (IPS), Threaded (FNPT), Flanged (ANSI 150), Socket (Metric)



IPEX

VT Series 3-Way Ball Valves

Sample Specification



1.0 Ball Valves - VT

1.1 Material

- The valve body, stem, ball, end connectors, and unions shall be made of PVC compound which shall meet or exceed the requirements of cell classification 12454 according to ASTM D1784.
- or The valve body, stem, ball, end connectors, and unions shall be made of stabilized PP homopolymer compound, also containing a RAL 7032 pigment, which shall meet or exceed the requirements of Type I Polypropylene according to ASTM D4101-86.
- These compounds shall comply with standards that are equivalent to NSF Standard 61 for potable water.

1.2 Seats

- The ball seats shall be made of Teflon® (PTFE) which shall comply with standards that are equivalent to NSF Standard 61 for potable water.

1.3 Seals

- The o-ring seals shall be made of EPDM which shall comply with standards that are equivalent to NSF Standard 61 for potable water.
- or The o-ring seals shall be made of Viton® (FPM) which shall comply with standards that are equivalent to NSF Standard 61 for potable water.

1.4 All other wetted and non-wetted parts of the valves shall comply with standards that are equivalent to NSF Standard 61 for potable water.

2.0 Connections

2.1 Socket style

- The IPS socket PVC end connectors shall conform to the dimensional standards ASTM D2466 and ASTM D2467.
- or The Metric socket PP end connectors shall conform to the dimensional standard ISO 3609.

2.2 Threaded style

- The female NPT threaded PVC end connectors shall conform to the dimensional standards ASTM D2464, ASTM F1498, and ANSI B1.20.1.
- or The female NPT threaded PP end connectors shall conform to the dimensional standards ASTM F1498, and ANSI B1.20.1.



VT Series 3-Way Ball Valves

Sample Specification (cont'd)



2.3 Flanged style

- The ANSI 150 flanged PVC end connectors shall conform to the dimensional standard ANSI B16.5.
- or The ANSI 150 flanged PP end connectors shall conform to the dimensional standard ANSI B16.5.

3.0 Design Features

- All valves shall be true union at all three ports.
- All sizes shall be full port.
- Valve design shall permit positive shutoff of any of the three ports.
- Balls shall be of T-port or L-port design (specifier must select one).
- The valve body, union nuts, and carrier shall have deep square style threads for increased strength.
- The ball shall be machined smooth to minimize wear on valve seats.
- All valve seats shall have o-ring backing cushions to compensate for wear and prevent seizure of the ball.
- The thickness of the valve body shall be the same at all three ports.
- The handle shall incorporate molded features to indicate port location and ball position.
- The top of the stem shall incorporate molded features to indicate port location and ball position.
- All valves shall have integrally molded mounting pads.

3.1 Pressure Rating

- All valves shall be rated at 150 psi at 73°F.

3.2 Markings

- All valves shall be marked to indicate size, material designation, and manufacturer's name or trade mark.

3.3 Color Coding

- All PVC valves shall be color-coded dark gray.
- or All PP valves shall be color-coded beige gray.

4.0 All valves shall be Xirtec® 140 or PP by IPEX or approved equal.



VT Series 3-Way Ball Valves

Valve Selection

Size (inches)	Body Material	Port Style	O-ring Material	IPEX Part Number			Pressure Rating @ 73°F
				IPS Socket	FNPT Threaded	ANSI Flanged	
1/2	PVC	T	EPDM	053403	053770	150 psi	
			Viton®	053429	053776		
		L	EPDM	053455	053782		
			Viton®	053481	053788		
3/4	PVC	T	EPDM	053404	053771		
			Viton®	053430	053777		
		L	EPDM	053456	053783		
			Viton®	053482	053789		
1	PVC	T	EPDM	053405	053772		
			Viton®	053431	053778		
		L	EPDM	053457	053784		
			Viton®	053483	053790		
1-1/4	PVC	T	EPDM	053406	053773		
			Viton®	053432	053779		
		L	EPDM	053458	053785		
			Viton®	053484	053791		
1-1/2	PVC	T	EPDM	053407	053774		
			Viton®	053433	053780		
		L	EPDM	053459	053786		
			Viton®	053485	053792		
2	PVC	T	EPDM	053408	053775		
			Viton®	053434	053781		
		L	EPDM	053460	053787		
			Viton®	053486	053793		

Size (inches)	Metric Size	Body Material	Port Style	O-ring Material	IPEX Part Number		Pressure Rating @ 73°F
					Metric Socket	ANSI Flanged	
1/2	20mm	PP	T	EPDM	053794	053806	150 psi
				Viton®	053800	053812	
			L	EPDM	053818	053830	
				Viton®	053824	053836	
3/4	25mm	PP	T	EPDM	053795	053807	
				Viton®	053801	053813	
			L	EPDM	053819	053831	
				Viton®	053825	053837	
1	32mm	PP	T	EPDM	053796	053808	
				Viton®	053802	053814	
			L	EPDM	053820	053832	
				Viton®	053826	053838	
1-1/4	40mm	PP	T	EPDM	053797	053809	
				Viton®	053803	053815	
			L	EPDM	053821	053833	
				Viton®	053827	053839	
1-1/2	50mm	PP	T	EPDM	053798	053810	
				Viton®	053804	053816	
			L	EPDM	053822	053834	
				Viton®	053828	053840	
2	63mm	PP	T	EPDM	053799	053811	
				Viton®	053805	053817	
			L	EPDM	053823	053835	
				Viton®	053829	053841	

Body Material:

- PVC PP

Port:

- T L

Size (inches):

- 1/2 1-1/4
 3/4 1-1/2
 1 2

- 20mm 40mm
 25mm 50mm
 32mm 63mm

Seals:

- EPDM
 Viton® (FPM)

End Connections:

- Socket (IPS)
 Threaded (FNPT)
 Flanged (ANSI 150)
 Socket (Metric)

IPEX Part Number:



VT Series 3-Way Ball Valves

Technical Data

dimensions

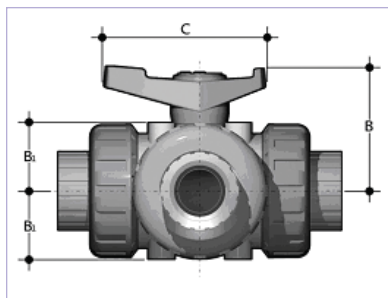

Dimension (inches)				
Size	d	B	C	B ₁
1/2	0.84	2.01	2.56	1.08
3/4	1.05	2.36	2.99	1.28
1	1.32	2.64	3.35	1.44
1-1/4	1.66	2.95	3.94	1.69
1-1/2	1.90	3.50	4.41	2.03
2	2.38	4.13	5.39	2.34

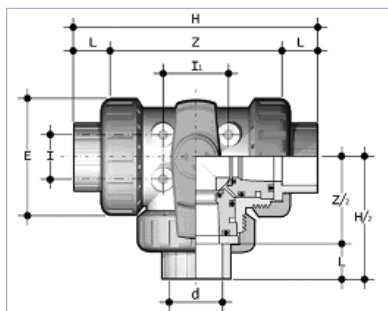

IPS Socket Connections - Dimension (inches)							
Size	d	L	Z	H	E	I ₁	I
1/2	0.84	0.89	3.03	4.80	2.09	0.94	0.94
3/4	1.05	1.00	3.58	5.59	2.44	1.22	0.98
1	1.32	1.13	3.96	6.22	2.80	1.57	1.06
1-1/4	1.66	1.26	4.92	7.44	3.31	1.61	1.26
1-1/2	1.90	1.38	5.31	8.07	3.86	2.09	1.10
2	2.38	1.50	6.56	9.57	4.61	2.28	1.38

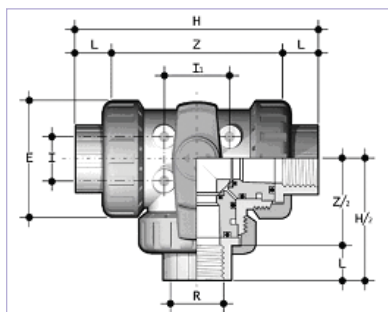

Female NPT Threaded Connections - Dimension (inches)							
Size	R	L	Z	H	E	I ₁	I
1/2	1/2-NPT	0.70	3.17	4.57	2.09	0.94	0.94
3/4	3/4-NPT	0.71	3.69	5.10	2.44	1.22	0.98
1	1-NPT	0.89	4.15	5.93	2.80	1.57	1.06
1-1/4	1-1/4-NPT	0.99	5.12	7.09	3.31	1.61	1.26
1-1/2	1-1/2-NPT	0.97	5.50	7.44	3.86	2.09	1.10
2	2-NPT	1.17	6.73	9.06	4.61	2.28	1.38

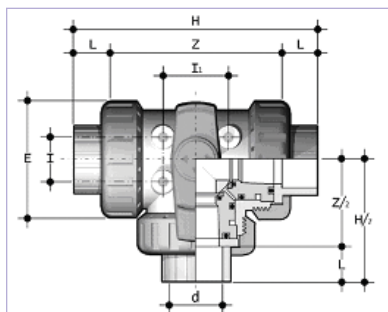

Metric Socket Connections - Dimension (inches)							
Size	d	L	Z	H	E	I ₁	I
1/2	0.84	0.57	3.23	4.37	2.09	0.93	0.93
3/4	1.05	0.63	3.74	5.00	2.48	1.20	0.96
1	1.32	0.71	4.29	5.71	2.80	1.55	1.04
1-1/4	1.66	0.81	5.12	6.73	3.31	1.58	1.24
1-1/2	1.90	0.93	6.10	7.95	3.82	2.05	1.10
2	2.38	1.08	7.20	9.37	4.57	2.22	1.34



VT Series 3-Way Ball Valves

Technical Data (cont'd)

dimensions cont'd

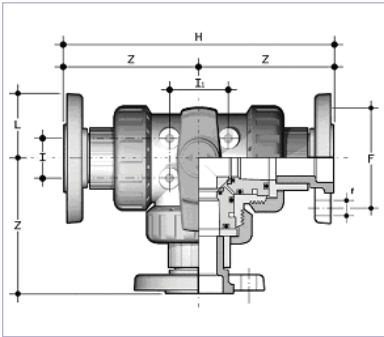

ANSI 150 Flanged (Vanstone) Connections - Dimension (inches)													
Size	# of holes	f	F	PVC					PP				
				L	Z	H	I ₁	I	L	Z	H	I ₁	I
1/2	4	5/8	2-3/8	1.75	3.31	6.61	0.94	0.94	1.88	3.23	6.45	0.93	0.93
3/4	4	5/8	2-3/4	1.94	3.76	7.53	1.22	0.98	2.02	3.62	7.24	1.20	0.96
1	4	5/8	3-1/8	2.13	4.17	8.35	1.57	1.06	2.25	4.07	8.13	1.55	1.04
1-1/4	4	5/8	3-1/2	2.31	4.81	9.63	1.61	1.26	2.56	4.64	9.27	1.58	1.24
1-1/2	4	5/8	3-7/8	2.50	5.29	10.57	2.09	1.10	2.62	5.37	10.73	2.05	1.10
2	4	3/4	4-3/4	3.00	6.16	12.32	2.28	1.38	3.17	6.24	12.47	2.22	1.34

weights

Size	Approximate Weight (lbs)				
	PVC			PP	
	IPS Socket	FNPT Threaded	ANSI Flanged	Metric Socket	ANSI Flanged
1/2	0.54	0.53	1.14	0.39	1.94
3/4	0.85	0.80	1.72	0.60	2.60
1	1.23	1.25	2.41	0.88	4.11
1-1/4	1.93	1.86	3.43	1.36	5.31
1-1/2	2.84	2.73	4.64	1.90	6.37
2	4.60	4.41	7.41	3.09	9.74

pressure – temperature ratings

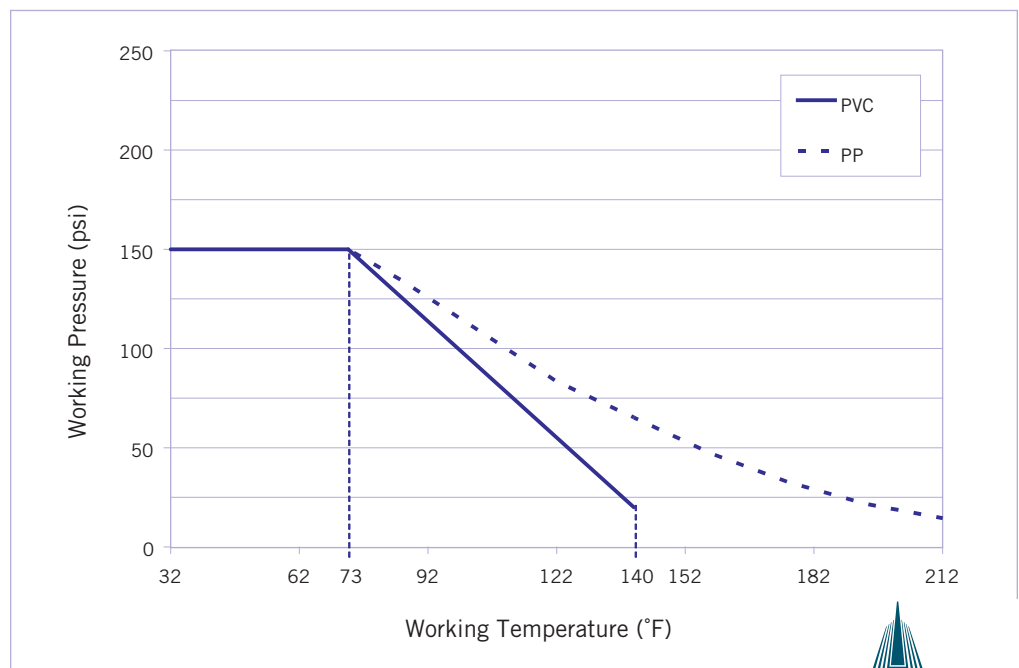

VT Series 3-Way Ball Valves

Technical Data (cont'd)



operating positions

Position	T-Port	L-Port
0°	mixing	diverting
90°	diverting	closed
180°	straight flow	closed
270°	diverting	diverting

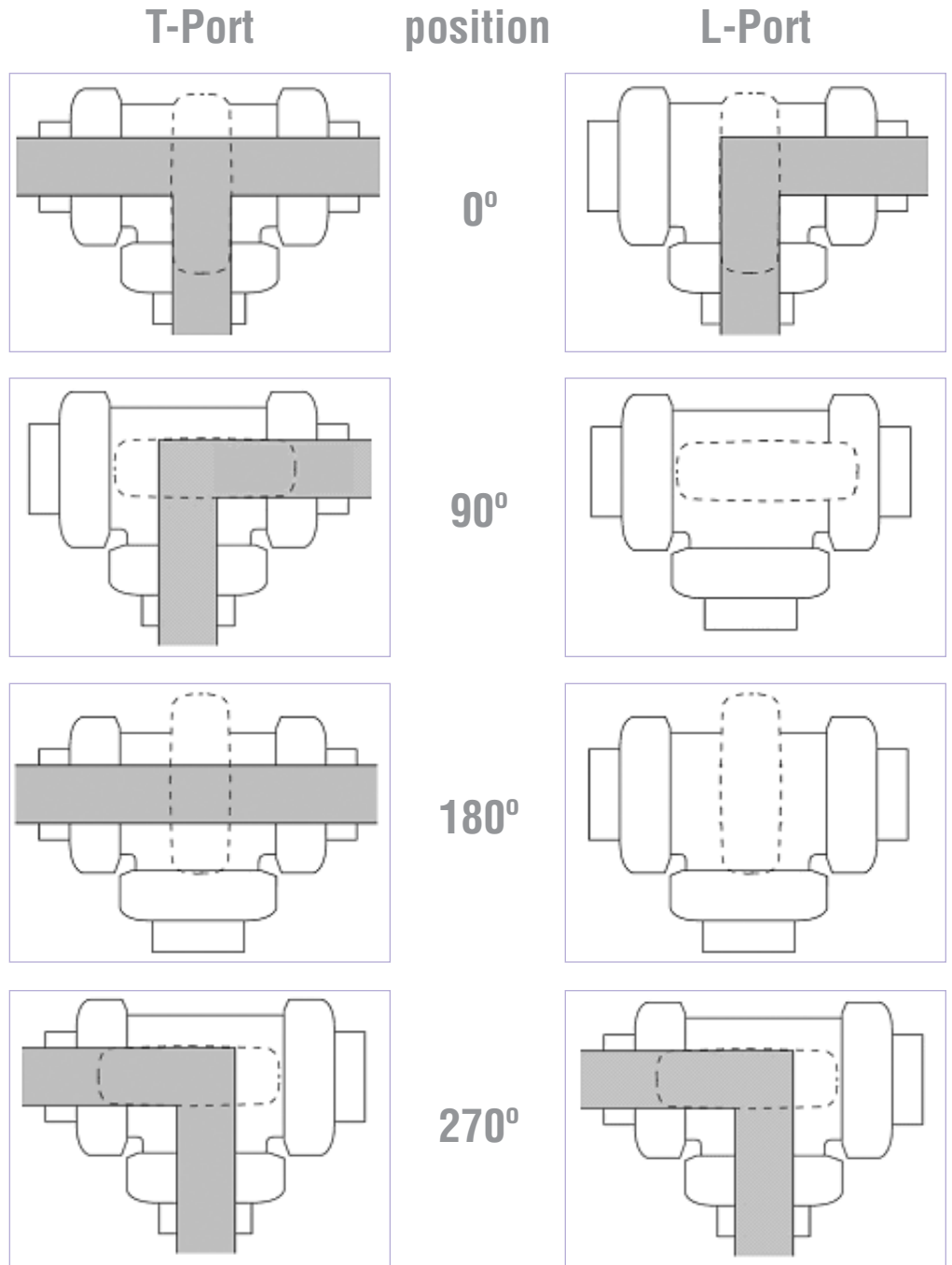

VT Series 3-Way Ball Valves

Technical Data (cont'd)



flow coefficients

The flow coefficient (CV) represents the flow rate in gallons per minute (GPM) at 68°F for which there is a 1 psi pressure drop across the valve in the fully open position. These values are determined from an industry standard testing procedure which uses water as the flowing media (specific gravity of 1.0). To determine specific flow rate and pressure loss scenarios, one can use the following formula:

$$f = sg \times \left(\frac{Q}{C_v} \right)^2$$

Where,

f is the pressure drop (friction loss) in psi,

sg is the specific gravity of the fluid,

Q is the flow rate in GPM,

C_v is the flow coefficient.

Size	C _v Value				
	Position				
	A	B	C	D	E
1/2	3.85	2.45	4.55	13.7	5.11
3/4	9.50	6.65	10.2	26.6	10.5
1	14.4	9.80	17.2	53.2	18.6
1-1/4	27.3	18.9	32.2	73.5	33.3
1-1/2	33.3	23.1	42.0	119	43.4
2	63.0	43.4	84.0	224	85.4

pressure loss chart

Position A:

- T-Port
- Center Inlet
- Diverting Flow

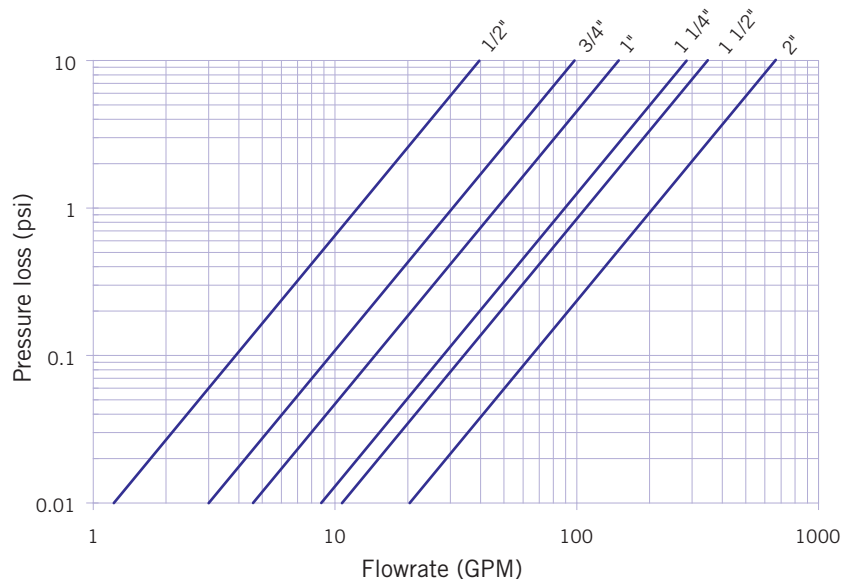
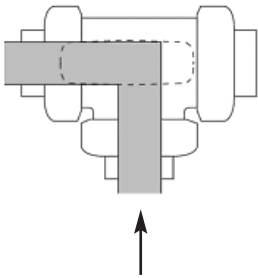

VT Series 3-Way Ball Valves

Technical Data (cont'd)

pressure loss charts (cont'd)

Position B:

- T-Port
- Center Inlet
- Separating Flow

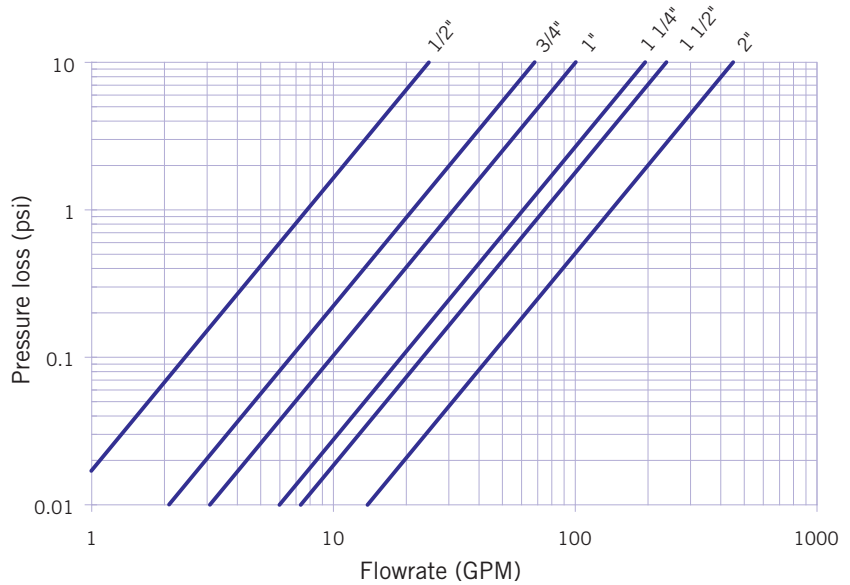
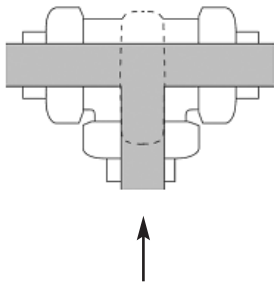

Position C:

- T-Port
- Side Inlet
- Diverting Flow

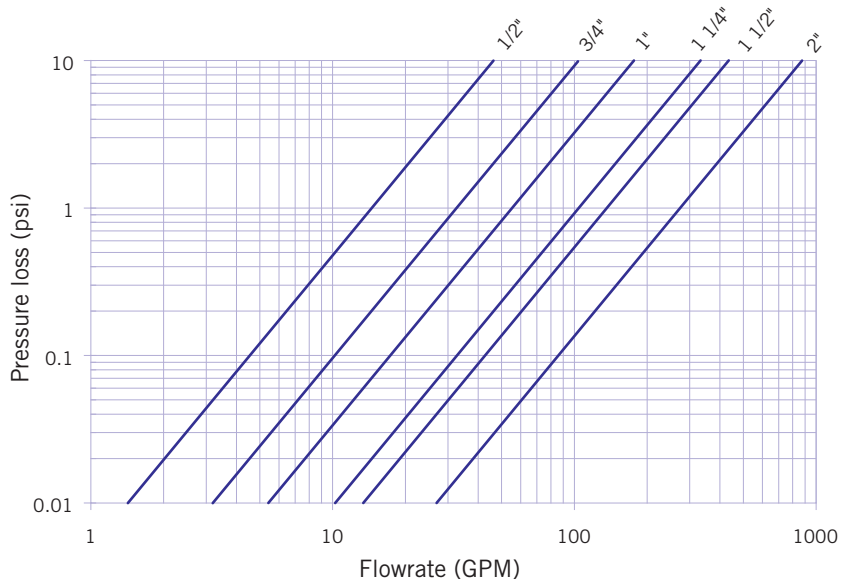
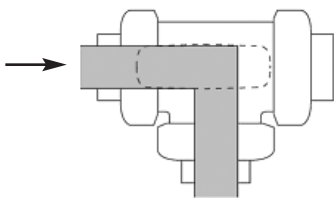

VT Series 3-Way Ball Valves

Technical Data (cont'd)

pressure loss charts (cont'd)

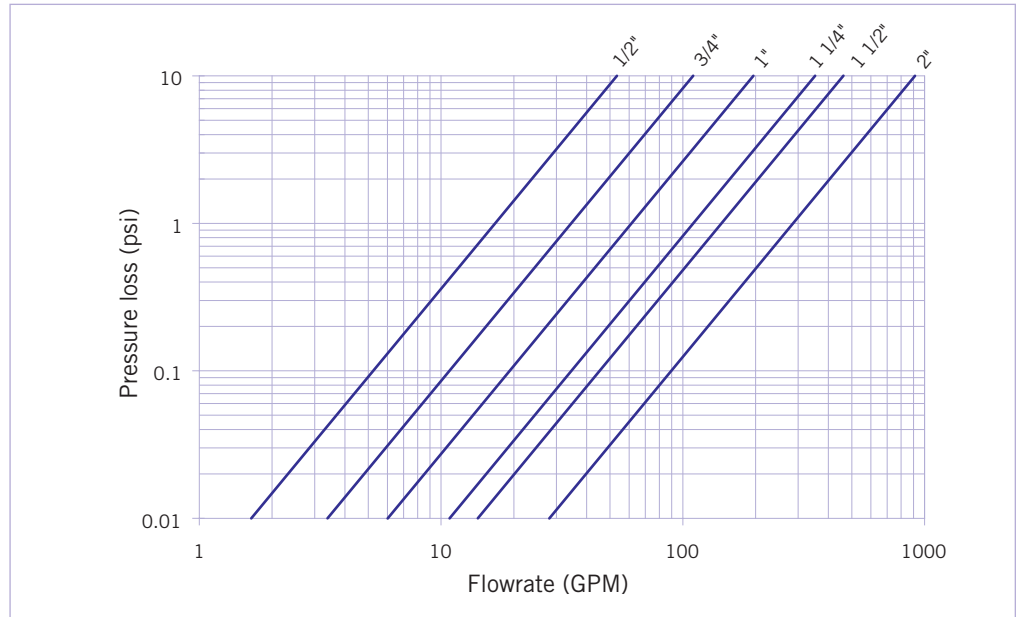
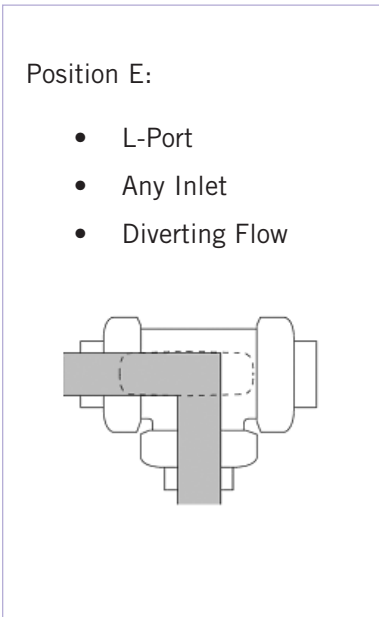
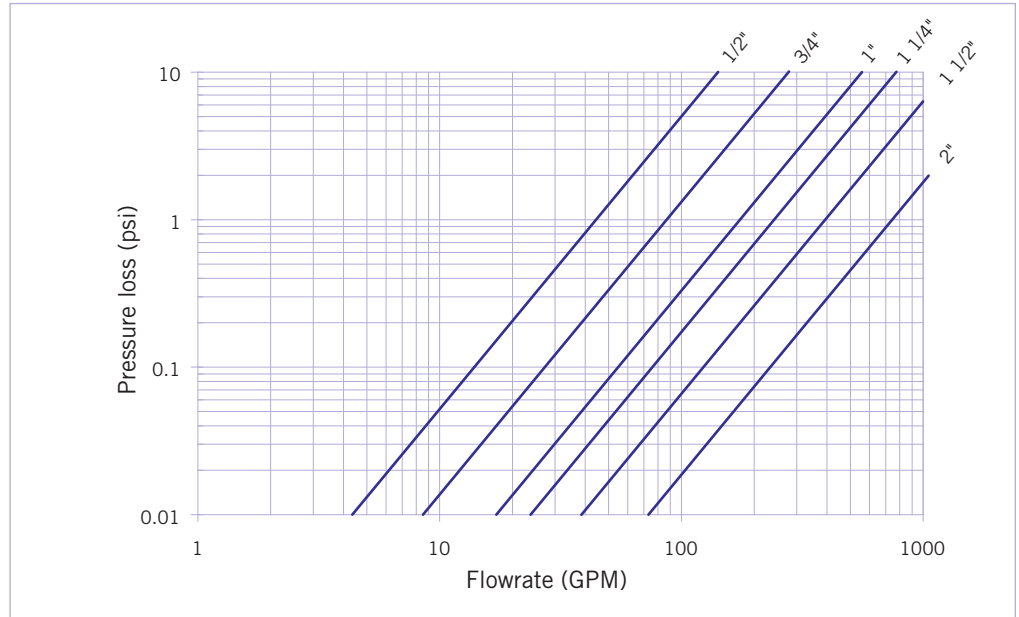
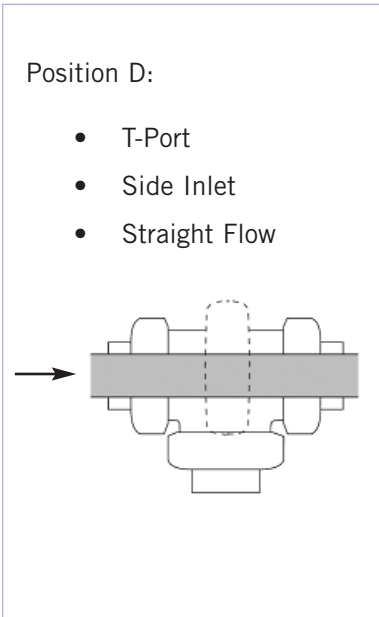

VT Series 3-Way Ball Valves

Components

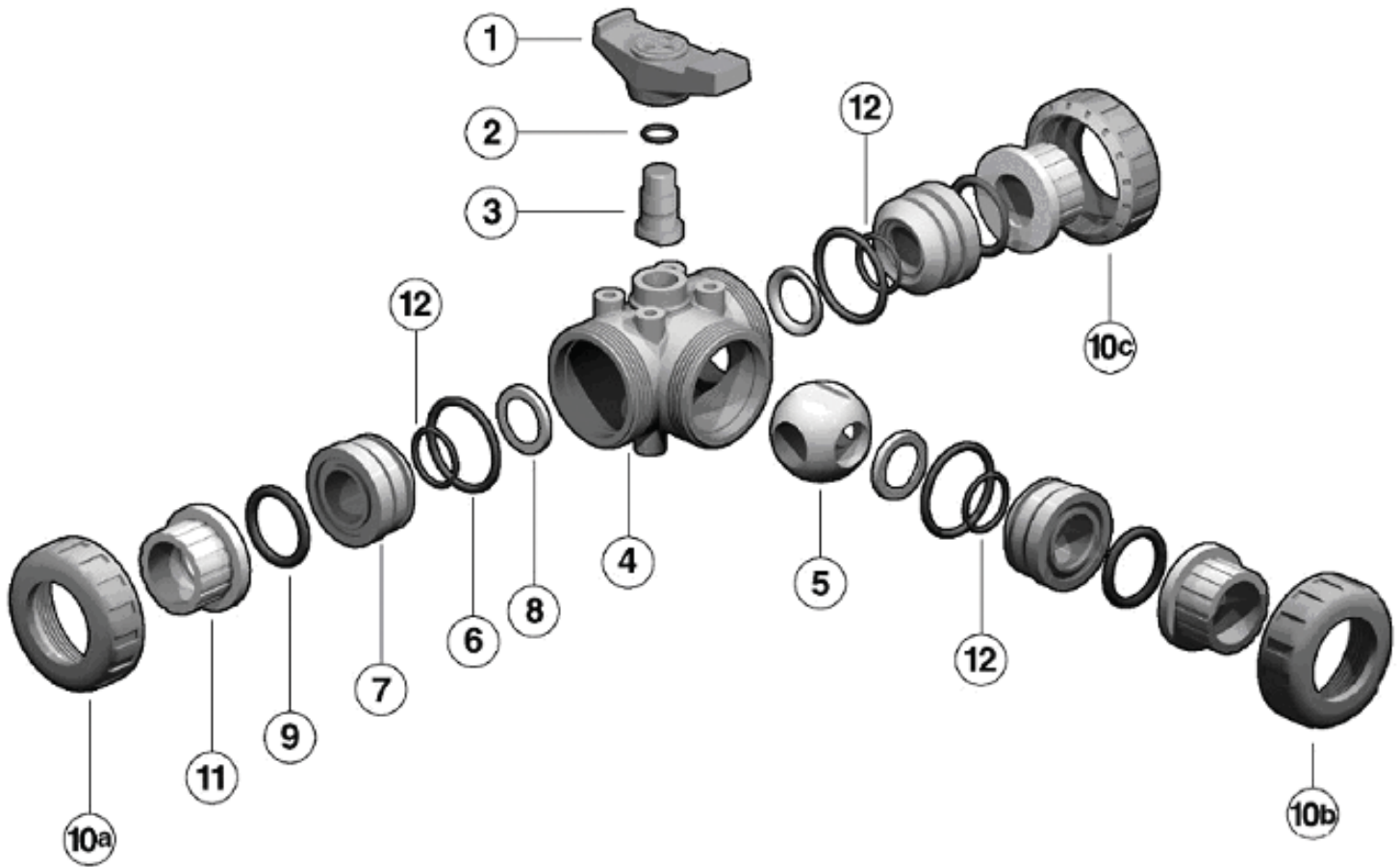

#	Component	Material	Qty
1*	handle	High Impact PVC	1
2*	stem o-ring	EPDM or Viton®	1
3*	stem	PVC / PP	1
4	body	PVC / PP	1
5*	ball	PVC / PP	1
6*	body o-ring	EPDM or Viton®	3
7	support for ball seat	PVC / PP	3
8*	ball seat	PTFE	3
9*	socket o-ring	EPDM or Viton®	3
10*	union nut	PVC / PP	3
11*	end connector	PVC / PP	3
12	backing o-ring	EPDM or Viton®	3

* Spare parts available.



VT Series 3-Way Ball Valves

Installation Procedures



1. For socket and threaded style connections, remove the union nuts (part #10 on previous page) and slide them onto the pipe. For flanged connections, remove the union nut / flange assemblies from the valve.
2. Please refer to the appropriate connection style sub-section:
 - a. For socket style, solvent cement the end connectors (11) onto the pipe ends. For correct joining procedure, please refer to the section entitled, *“Joining Methods – Solvent Cementing”* in the IPEX Industrial Technical Manual Series, *“Volume I: Vinyl Process Piping Systems”*. **Be sure to allow sufficient cure time before continuing with the valve installation.**
 - b. For threaded style, thread the end connectors (11) onto the pipe ends. For correct joining procedure, please refer to the section entitled, *“Joining Methods – Threading”* in the IPEX Industrial Technical Manual Series, *“Volume I: Vinyl Process Piping Systems”*.
 - c. For flanged style, join the union nut / flange assemblies to the pipe flanges. For correct joining procedure, please refer to the section entitled, *“Joining Methods – Flanging”* in the IPEX Industrial Technical Manual Series, *“Volume I: Vinyl Process Piping Systems”*.
3. Ensure that the socket o-rings (9) are properly fitted in their grooves then carefully place the valve in the system between the end connections.
4. Tighten the union nut on the side marked “TIGHTEN” (10a). Hand tightening is typically sufficient to maintain a seal for the maximum working pressure. **Over-tightening may damage the threads on the valve body and/or the union nut, and may even cause the union nut to crack.**
5. Tighten the remaining two union nuts (10b and 10c). Tightening the union nuts in this order results in the best possible valve performance due to optimum positioning and sealing of the ball and seat support system.
6. Open and close the valve to ensure that the cycling performance is adequate. If adjustment is required, loosen and/or tighten only the 10b and 10c union nuts.



VT Series 3-Way Ball Valves

Valve Maintenance

disassembly



1. If removing the valve from an operating system, isolate the valve from the rest of the system. **Be sure to depressurize and drain the isolated branch and valve before continuing.**
2. Loosen the three union nuts (10) and drop the valve out of the line. If retaining the socket o-rings (9), take care that they are not lost when removing the valve from the line.
3. To disassemble, turn the handle (1) to a position parallel with the two side ports of the valve body (4).
4. Carefully press the ball (5) and support (7) out of the valve body from one of the side ports, taking care not to score or damage the sealing surfaces.
5. Remove the remaining two seat supports from the valve body.
6. Remove the handle (1) from the stem (3). Press the stem into the valve body from above to remove.
7. The stem o-ring (2), body o-rings (6), ball seats (8), and backing o-rings (12) can now be removed and/or replaced.

assembly



Note: Before assembling the valve components, it is advisable to lubricate the o-rings with a water soluble lubricant. **Be sure to consult the "IPEX Chemical Resistance Guide" and/or other trusted resources to determine specific lubricant-rubber compatibilities.**

1. Properly fit the stem o-ring (2) in the groove on the stem (3), then insert the stem from the inside of the valve body (4).
2. Line up the markings on the stem with the ports in the valve body.
3. Insert the ball (5) into the valve body while ensuring that the ports line up with the markings on the stem.
4. Ensure that the backing o-rings (12), ball seats (8), and body o-rings (6) are all properly fitted on the three seat supports (7) then carefully insert each of them into the valve body.
5. Replace the handle (1) on the stem while ensuring that the position markings on the handle line up with those on the stem.
6. Properly fit the socket o-rings (9) in their respective grooves.
7. Place the end connectors (11) into the union nuts (10), then thread onto the valve body taking care that the socket o-rings remain properly fitted in their grooves.



VT Series 3-Way Ball Valves

Testing and Operating



The purpose of system testing is to assess the quality of all joints and fittings to ensure that they will withstand the design working pressure, plus a safety margin, without loss of pressure or fluid. Typically, the system will be tested and assessed in sub-sections as this allows for improved isolation and remediation of potential problems. With this in mind, the testing of a specific installed valve is achieved while carrying out a test of the overall system.

An onsite pressure test procedure is outlined in the IPEX Industrial Technical Manual Series, *"Volume I: Vinyl Process Piping Systems"* under the section entitled, *"Testing"*. The use of this procedure should be sufficient to assess the quality of a valve installation. **In any test or operating condition, it is important to never exceed the pressure rating of the lowest rated appurtenance in the system.**

Important points:

- Never test thermoplastic piping systems with compressed air or other gases including air-over-water boosters.
- When testing, do not exceed the rated maximum operating pressure of the valve.
- Avoid the rapid closure of valves to eliminate the possibility of water hammer which may cause damage to the pipeline or the valve.

Please contact IPEX customer service and technical support with regard to any concern not addressed in this data sheet or the technical manual.

VT Series 3-Way Ball Valves

About IPEX

IPEX is a leading supplier of thermoplastic piping systems. We provide our customers with one of the world's largest and most comprehensive product lines. All IPEX products are backed by over 50 years of experience. With state-of-the-art manufacturing facilities and distribution centers across North America, the IPEX name is synonymous with quality and performance.

Our products and systems have been designed for a broad range of customers and markets. Contact us for information on:

- PVC, CPVC, PP, FR-PVDF, ABS, PEX and PE pipe and fittings ($\frac{1}{4}$ " to 48")
- Industrial process piping systems
- Double containment systems
- Acid waste systems
- High purity systems
- Industrial, plumbing and electrical cements
- Municipal pressure and gravity piping systems
- Plumbing and mechanical pipe systems
- Electrical systems
- Telecommunications systems
- Irrigation systems
- PE Electrofusion systems for gas and water
- Radiant heating systems

WARRANTY: All IPEX products are guaranteed against defects resulting from faulty workmanship or materials. If any such product is found to be defective by reason of faulty workmanship or materials, upon written notice and return of the product, the defective product will be replaced by IPEX free of charge, including shipping charges for the replacement product. Claims for labour costs and other expenses required to replace such defective product or to repair any damage resulting from the use thereof will not be allowed by IPEX. Our liability is limited to the price paid for the defective product. IPEX will not be bound by any warranty, other than the above set forth, unless such warranty is in writing.

This literature is published in good faith and is believed to be reliable. However, it does not represent and/or warrant in any manner the information and suggestions contained in this brochure. Data presented is the result of laboratory tests and field experience.

A policy of ongoing product improvement is maintained. This may result in modification of features and/or specifications without notice.

Products manufactured by IPEX Inc. and distributed in the United States by IPEX USA LLC.

Cda Toll Free: 866-473-9462 • www.ipexinc.com

U.S. Toll Free: 800-463-9572 • www.ipexamerica.com

